

TEXWRAP® 2219/3322

MADE IN U.S.A

AUTOMATIC IN-LINE L-SEALERS

Features, Functions & Benefits

- **New!** Improved production rates
- **New!** 240 Volt AC Power
- **New!** Inverter duty AC motors for maximum reliability
- **New!** Swing arm control panel for easy operator access
- **New!** Low profile "lay-on" cradle with power film unwind now comes standard
- **New!** Enhanced guarding now standard
- **New!** "Smooth Mate" contoured exit conveyor for optimum transfer of products
- **New!** Multi-packing feature creates single lane unitizing into one package.
- Variable speed belts(20-100 FPM)
- MOTION TRIM™ technology to increase cycle rate
- Automatic dwell time compensator
- Tubular steel construction with powder coat finish
- Thermostatically controlled hot knife seal system provides efficient long term operation
- Front or rear product edge trip



Now...Even More New Features!

- Password protected user levels
- Product Library
- Advanced Controls option available

Distributed by:



525 Vossbrink Drive · Washington, MO 63090
Ph (636)239-7424 · Fax (636) 239-7322
sales@texwrap.com · www.texwrap.com

TEXWRAP

2219 & 3322 Automatic L-Sealers

NOTE:
ALLOW 78" MINIMUM
FOR MACHINE HEIGHT

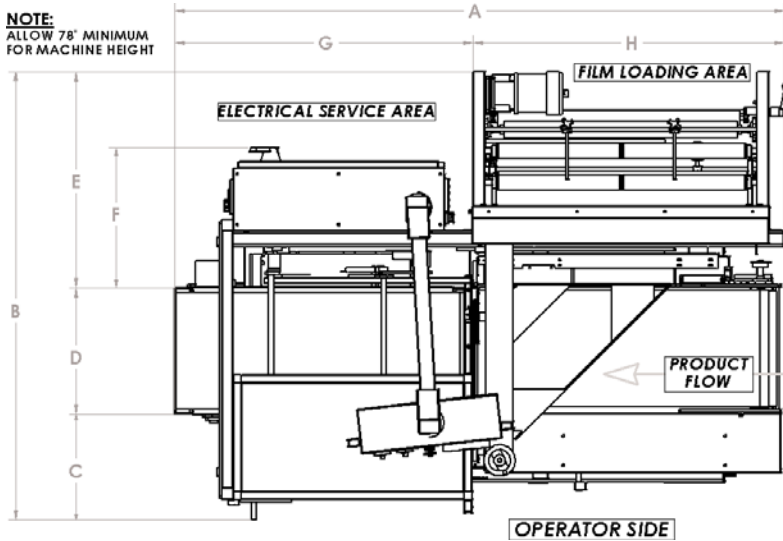

SPECIFICATIONS	2219	3322
MAXIMUM PKG SIZE	19"L x 15.5"W x 7"H	32"L x 19.5"W x 10.5"H
	*Maximum dimensions cannot be combined	
MINIMUM PKG SIZE	4"L x 2-3/4"W (standard)	
	2"L x 2-3/4"W (with closing conveyor)	
FILM WIDTH	Max. 28" CF/ Min. 6" CF	
	54" and 72" Flat Film available	
ELECTRICAL	240 Volts AC Power, 1 phase	
AIR REQUIREMENTS	1.5 CFM @ 80 PSI	
CONVEYOR HEIGHT	Adj. From 29.5" to 36" H	
MAXIMUM PKGS PER MINUTE	Up to 50 Pkg per minute (speeds based on pkg size, configuration and optional features)	
SHIPPING WEIGHT	1400 LBS	1800 LBS

	A	B	C	D	E	F	G	H
2219	78"	57-1/2"	12-3/4"	16-1/4"	28-1/2"	18"	38-1/2"	39-1/2"
3322	96-1/2"	62"	12-3/4"	20-1/2"	28-1/2"	17-3/4"	54-1/4"	42-1/4"

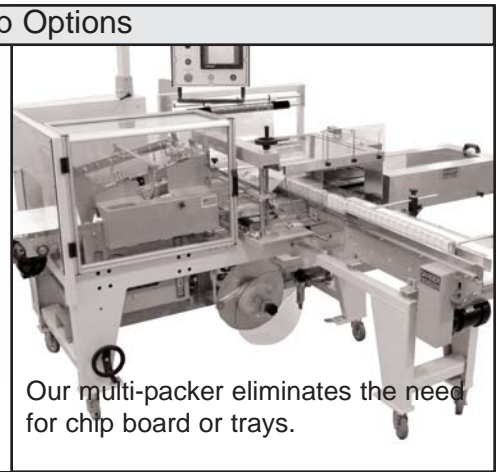
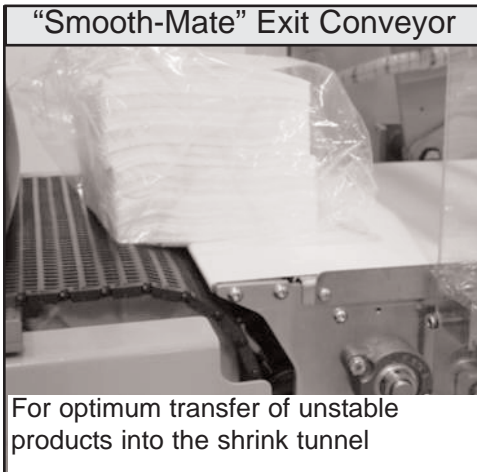

ADD OTHER TEXWRAP EQUIPMENT FOR A COMPLETE SYSTEM:

INFEEDS:	Belted Conveyor	Flighted Conveyor	Flightbar Conveyor
Texwrap produces a full range of infeed conveyors from simple belt, lug, and flight bar to Servo placement systems that will enhance the operation of the wrapper.			
TUNNELS:	Single Tunnel	Double Tunnel	Tunnel Window
Cool-Touch insulated Texwrap Tunnels offer the proper balance between cost, versatility and durability. These tunnels are designed for multiple shifts 24/7 operation. Optional lighted window on all models.			

V1.0

TEXWRAP

PO BOX 185, 525 VOSSBRINK DR, WASHINGTON MO 63090
PH (636) 239-1188 · FAX (636) 239-7322
WWW.TEXWRAP.COM · SALES@TEXWRAP.COM

*Specifications on all machines subject to change without notice. Some information may have been updated since the time of publication.